



Chorus UFB Services Agreement
Service Description for Bitstream 3

1 Interpretation

- 1.1 The Bitstream 3 Service described in this Service Description will be available from the date it is launched by the LFC. The LFC will notify the Service Provider of the launch date for the Bitstream 3 Service.
- 1.2 References to clauses or sections are references to clauses or sections in this Service Description unless expressly provided otherwise. The definitions set out in the General Terms and the Operations Manual apply to this Service Description unless expressly provided otherwise.
- 1.3 References to the Operations Manual are references to the operations manual for the Bitstream Services.

2 The Bitstream 3 Service

- 2.1 The Bitstream 3 Service is a single-class bitstream service suitable for complex business grade applications and premium residential products delivered over a shared fibre access. Bitstream 3 is part of the UFB family of bitstream services:

Bitstream 2	Based on the TCF Mass Market service.
Bitstream 3	Based on the TCF Business service.
Bitstream 3a	Based on the TCF Business service with Low Priority options.
Bitstream 4	Based on the TCF Business Premium service.
UFB Handover Connection	Based on the TCF E-NNI specification.
Multicast	Based on the TCF Ethernet Multicast Access (EMA) service.
ATA Voice	An analogue telephone access service.

- 2.2 A diagram of the configuration for the Bitstream 3 Service is set out in Appendix A. The Bitstream 3 Service provides an Ethernet bitstream service from the UNI at the End User Premises to the UFB Handover Connection Service located at the POI that enables a Service Provider to access and interconnect with the LFC Network.
- 2.3 The Bitstream 3 Service is an input service which a Service Provider can combine with other LFC services (or with the Service Provider's own network or wholesale services provided by other service providers) to provide fibre based telecommunications services to End Users.
- 2.4 The Bitstream 3 Service has the following key characteristics:
- 2.4.1 The Bitstream 3 Service includes one or more Ethernet E-APL bitstream services delivered in conjunction with Baseband over GPON. In particular
- (a) Each Ethernet E-APL bitstream service allows up to 4093 VLANS to be passed transparently between the UNI and the E-NNI; and
 - (b) The Baseband service supports up to two instances of the ATA Voice Service.
- 2.4.2 Support for one class of traffic, High Priority.
- 2.4.3 A range of Service Template package offers. A single Service Template is initially offered, consisting of a single Ethernet E-APL bitstream with a range of bandwidth options and a single ATA Voice Service package with the option to create modified or

new Service Templates using 'core building blocks' and the Product Development Process.

- 2.4.4 Supports tagged or untagged traffic by the End User.
- 2.4.5 Complies with the Business service specified in the *TCF Ethernet Access Service Description v24, 19 January 2011*.

3 Bitstream 3 Service and implementation activities

Installation Services

- 3.1 The Bitstream 3 Service includes a Standard Install as set out below (in each case to the extent that the relevant provisioning works are not already complete for the relevant Service Order).¹

Provisioning at Single Dwelling Unit End User's Premises

- 3.1.1 A Standard Install for the Bitstream 3 Service to a Single Dwelling Unit includes:
 - (a) a Fibre Lead-in from the Fibre Access Point to an ETP at the closest convenient point on the End User Premises, as agreed with End User, where the Fibre Lead-in utilises no more than:
 - (i) 100m of approved conduit or open trench (already in place at the time of installation); or
 - (ii) a single span of aerial drop lead (available only in areas where there is overhead deployment); or
 - (iii) 15m of buried lead-in (available only in areas where there is underground deployment); and
 - (b) an extension of the Fibre Lead-in up to 5m from the ETP (there will not necessarily be a break in the Fibre Lead-in at the ETP) to:
 - (i) a suitable mounted SC/APC connector at a secure location inside the End User Premises; or
 - (ii) if there is an ODF beyond the ETP, a splice or LCA connector on the ODF.
- 3.1.2 The LFC will provide Non-Standard Installs for the Bitstream 3 Service to Single Dwelling Units as an ancillary service.

Provisioning at MDU End User's Premises

- 3.1.3 A Standard Install for the Bitstream 3 Service to an End User that is within a MDU where there is no LFC network fibre within the Premises, includes a Fibre Lead-in from the Fibre Access Point to the ODF or equivalent at the closest convenient point within the MDU, as agreed with the MDU owner or their agent, where the Fibre Lead-in utilises no more than:
 - (a) 100m of approved conduit or open trench (already in place at the time of installation); or
 - (b) a single span of aerial drop lead (available only in areas where there is overhead deployment); or
 - (c) 15m of buried lead-in (available only in areas where there is underground deployment).
- 3.1.4 Where the fibre cabling in a MDU to the End User Tenancy is not already in place at the time of installation of the Bitstream 3 Service, the LFC will work with the building owners,

¹ Standard Install parameters may differ between LFCs

their agents and the Service Provider using the MDU On Boarding Process described in the Operations Manual to provide fibre cabling within the MDU to extend the Fibre-Lead-in to the End-User Tenancy.

- 3.1.5 Once LFC Network fibre is installed to a MDU and a Fibre Lead-in to the required End User Tenancies, a Standard Install for the Bitstream 3 Service includes further extension of the Fibre Lead-in up to 5m from the ETP at the End User Tenancy. (there will not necessarily be a break in the Fibre Lead-in at the ETP) to:
- (a) a suitable mounted connector at a secure location; or
 - (b) if there is an OFDF beyond the ETP, a splice or LCA Connector on the OFDF, within the End User Tenancy.
- 3.1.6 If there is not an ETP at the End User Tenancy as contemplated by clause 3.1.5, a Standard Install for the Bitstream 3 Service includes further extension of the Fibre Lead-in up to 5m from the boundary of the End User Tenancy. to:
- (a) a suitable mounted SC/APC connector at a secure location; or
 - (b) if there is an OFDF beyond the boundary, a splice or LCA connector on the OFDF
- within the End User Tenancy.
- 3.1.7 The extended LFC Network fibre within the MDU is the Fibre Lead-in to an End User Tenancy, whether currently in use or not. The Fibre Lead-in is only available for use by the LFC.
- 3.1.8 Where the Service Provider requests provision of the Bitstream 3 Service to an End User Tenancy prior to the installation of fibre cabling in the MDU (as described in clause 3.1.4) then any Fibre Lead-in beyond the limits in clause 3.1.3 will be a Non-Standard Install.
- 3.1.9 The LFC will provide Non-Standard Installs for the Fibre Lead-in to MDUs as an ancillary service. .

Single Dwelling Unit Termination Point

- 3.1.10 For a Single Dwelling Unit, the termination point of the Layer 1 component of the Bitstream 3 Service for the purposes of the Connection at the End User's Premises, and the network demarcation point between the LFC Network and the Premises wiring is, as applicable, either:
- (a) the SC/APC connector on the end of the Fibre Lead-in from the ETP (which is the connector); or
 - (b) a splice or LCA connector on the OFDF,
- provided that any ONT installed by the LFC as part of the Bitstream 3 Service will also be part of the LFC Network.
- 3.1.11 The termination point of the Layer 2 component of the Bitstream 3 Service is the 100/1000Base-T UNI on the ONT.

MDU Termination Point

- 3.1.12 For MDUs, the termination point of the Layer 1 component of the Bitstream 3 Service for the purposes of the Connection at the End User's Tenancy, and the network demarcation point is as applicable, either:
- (a) the SC/APC connector on the end of the Fibre Lead-in (which is the jack); or
 - (b) a splice or LCA connector on the OFDF
- within the End User Tenancy, provided that any ONT installed by the LFC as part of the Bitstream 3 Service will also be part of the LFC Network.

- 3.1.13 The termination point of the Layer 2 component of the Bitstream 3 Service is the 100/1000Base-T UNI on the ONT.

Alternative Termination Points

- 3.1.14 The LFC and the Service Provider may agree on a different termination point as part of a Non-Standard Install. This may be necessary where, for example, there is installation to a NBAP. A Non Standard Install for a Bitstream 3 Service within a Multi Dwelling Unit will not include termination in a building common area or other facility made available by the owner to service the Multi Dwelling Unit, where a Fibre Lead-in has not been extended from the OFDF to the inside of an End User Tenancy.

Installation of ONT

- 3.1.15 A Standard Install for the Bitstream 3 Service includes installation of an ONT including:
- (a) supply and fixing of the ONT to structure of End User Premises (in the case of a Single Dwelling Unit or a MDU where a Fibre Lead-in has been extended to the inside of the End User Tenancy as anticipated in clause 3.1.4);
 - (b) supply and connection of fibre pigtail up to 1m long between the Fibre Lead-in termination point and the ONT if required; and
 - (c) testing from the UNI port of the ONT to ensure the Bitstream 3 Service is within the technical specification set out in Appendix B.
- 3.1.16 The Service Provider must ensure the End User provides a suitably located mains power outlet for the ONT power supply which is not provided as part of a Standard Installation.

Testing

- 3.2 The LFC will test the Fibre Lead-in from the termination point at the End User's Premises referred to in clause 3.1.10 and 3.1.12 to the Central Office where the access node is located to ensure the fibre is within the technical specification for fibre set out in Appendix B.

Additional Services

- 3.3 If the Service Provider requires additional services such as:
- (a) a Non-Standard Install which includes (where required):
 - (i) an extension in a MDU of the Fibre Lead-in from the OFDF to an ONT inside the End User's Tenancy where there is no existing fibre cabling at the MDU and the installation is outside the parameters set out in clause 3.1.3 ; or
 - (ii) installation to a NBAP utilising specialised termination equipment; or
 - (iii) installation of Fibre-Lead-in diversity at an End User's Premises (from the FAP to the ETP or OFDF as applicable);
 - (b) provision of diversity to End User's Premises (when the second or subsequent instance of the Bitstream 3 Service is purchased);
 - (c) Premises wiring services; or
 - (d) installation and testing of Service Provider equipment and services,
- then the LFC may be able to provide items (b) to (d) on request subject to terms to be agreed between the LFC and the Service Provider. Item (a) is available on terms as set out in this Agreement.

Core Bitstream 3 Service

- 3.4 The core bitstream services provided as part of the Bitstream 3 Service are as follows:
- 3.4.1 An Ethernet E- APL Service that supports transparent pass-through of 802.1Q frames on a designated UNI on the ONT at the End User Premises.

- 3.4.2 Delivered over a single 802.1ad SVLAN on the E-NNI at the POI.
- 3.4.3 All tagged and untagged traffic sent from the End User is treated as High Priority.
- 3.4.4 One initial Service Template is available consisting of a Baseband Service with one instance of the ATA Voice Service and one Ethernet E-APL bitstream service, using the following parameters:
 - (a) access rate; and
 - (b) service bandwidth;
 as set out in the table below:

Access Rate	100/100 Mbps	
Service Bandwidth (High Priority CIR, EIR = 0)	Upstream	Downstream
	2.5 Mbps	2.5 Mbps
	10 Mbps	10 Mbps
	20 Mbps	20 Mbps
	30 Mbps	30 Mbps
	40 Mbps	40 Mbps
	50 Mbps	50 Mbps
	60 Mbps	60 Mbps
	70 Mbps	70 Mbps
	80 Mbps	80 Mbps
	90 Mbps	90 Mbps
	100 Mbps	100 Mbps

- 3.4.5 The Bitstream 3 Service has similar characteristics to the other services within the UFB family of Bitstream services as identified below:

Attribute	Bitstream 2	Bitstream 3	Bitstream 3a	Bitstream 4
Bitstream	E-AVPL	E-APL	E-APL	E-APL
High Priority	Yes	Yes	Yes	Yes
Low Priority	Yes	No	Yes	No
Service Bandwidths*	From 30/10 Mbps up to 100/50 Mbps	From 2.5Mbps up and downstream to 100/100 Mbps	100/100 Mbps with High Priority from 2.5Mbps	From 1 Mbps up to 10 GigE
MTU	2000 Bytes	2000 Bytes	2000 Bytes	9100
MAC addresses	16	64	64	Unlimited
Number of available UNIs	4 standard	4 standard	4 standard	1 with a second UNI available on request
L2CP support	No	No	No	Limited
Diversity	On request with limited	On request with limited	On request with	Available to Priority Users

	availability	availability	limited availability	in selected areas
--	--------------	--------------	----------------------	-------------------

* *Bandwidth options for each Bitstream Service are detailed in each Bitstream Service Description and further options can be developed using the Product Development Process.*

3.4.6 The standard ONT for the Bitstream 3 Service supports four 100/1000 Ethernet UNIs and two ATA Voice ports. Additional configurations are available on request.

UNI – NNI characteristics

3.4.7 The Bitstream 3 Service requires a dedicated UNI. Additional UNIs can be used for additional instances of the Bitstream 2 Service or Bitstream 3a Service.

3.4.8 The sum of High Priority traffic profiles of all services delivered at a UFB Handover Connection can exceed the UFB Handover Connection Service line rate. If there is insufficient line rate to deliver the High Priority traffic then frames will be randomly discarded and Service Levels do not apply. It is therefore the Service Provider's responsibility to shape and queue traffic appropriately.

New Service Template Options

3.5 A Service Provider may request that the LFC creates additional Service Templates as follows:

3.5.1 Additional Service Templates can be created using combinations of one more of the following set of standard building blocks:

- (a) Point-to-Point single VLAN Ethernet Bitstream service (E-AVPL) service using High Priority and Low Priority combinations as set out in the service description for the Bitstream 2 Service. Multiple E-AVPLs can be configured on the same or on different UNIs;
- (b) Point to Point VLAN (E-APL) service using High Priority combinations as set out in this Service Description and 3.5.2 below;
- (c) Point to Point VLAN (E-APL) service using High Priority and Low Priority combinations as set out in the service description for the Bitstream 3a Service;
- (d) Multicast VLAN Ethernet Bitstream service (EMA) using High Priority (CIR) only;
- (e) ATA Voice port;
- (f) UNI (100/1000 Base-T) port;
- (g) WiFi; and
- (h) Other services or attributes requested by the Service Provider and agreed by the LFC.

3.5.2 Bitstream 3 High Priority traffic combinations can be created using increments of 2.5 Mbps upstream and/or downstream.

3.6 Service Templates can be added incrementally to an existing service offer, or supplied as a stand-alone package.

3.6.1 Stand alone packages must include Baseband. Stand alone packages mean that the End User connection does not need to consume any other Service Templates in order for services to be provided.

3.6.2 Incremental packages can be added as an additional service to an End User who is already consuming one or more Service Templates.

3.6.3 Baseband is a required service for all End User connections. If the Service Template that includes Baseband is removed from an End User connection and an incremental Service Template remains, then Baseband will be added to the incremental Service Template for that End User.

- 3.7 Requests for additional Service Templates will be implemented and delivered through the Product Development Process. The Product Development Process includes determination of pricing, development, testing and implementation.
- 3.8 The LFC will comply with the Service Provider's request under clause 3.5 in a timely manner. In the event that demand for new Service Templates exceeds the LFC's capacity to deliver the new Service Templates then the LFC may prioritise the Service Template requests in accordance with the Operations Manual.

Operations, Administration and Maintenance

- 3.9 The Bitstream 3 Service will support Service Provider remote access to the ONT via a service management gateway for appropriate management. A Service Provider may request particular management attributes via the Product Development Process.
- 3.10 The Bitstream 3 Service will support Ethernet Service Operations and Maintenance (OAM) for service integrity testing, fault diagnostics and performance measurement using ITU Y.1731. OAM capability will be phased in as the functionality is developed and deployed in scale and may be updated or amended by the LFC from time to time.

Service Requirements

- 3.11 To use the Bitstream 3 Service the Service Provider must have the capability to access and interconnect with it, by one of the following:
- 3.11.1 co-locating Service Provider equipment at the POI using the UFB Handover Connection Service and Central Office and POI Co-location Service;
 - 3.11.2 connecting to third party co-location space at the POI using the UFB Handover Connection Service, and with the third party taking the Central Office and POI Co-location Service;
 - 3.11.3 connecting to a backhaul service at the POI; or.
 - 3.11.4 by using the Direct Fibre Access Service to connect to Service Provider equipment at a remote location within the Central Office area.

Additional Service Characteristics

- 3.12 The technical specification of the Bitstream 3 Service is set out in Appendix B.
- 3.13 The LFC will provide certain support and other assistance as part of the Bitstream 3 Service including:
- 3.13.1 an automated facility for Service Requests;
 - 3.13.2 an automated facility for fault notifications; and
 - 3.13.3 a tool to assist the Service Provider in determining the location and availability of the Bitstream 3 Service (pre-qualification),
- each as more particularly set out in the Operations Manual.
- 3.14 The Bitstream 3 Service specifically excludes:
- 3.14.1 the UFB Handover Connection Service;
 - 3.14.2 provision or maintenance of any cabling or connection or active device:
 - (a) beyond the service demarcation points described in clauses 4.1 and clause 5.1;
 - (b) between the jack terminating the LFC provided Fibre Lead-in and the ONT where that cabling or connection is not provided by the LFC and the LFC has not agreed to take responsibility for that cabling or connection.
 - 3.14.3 configuration, monitoring, operation, on-going support or maintenance of Service Providers' or End User's applications, equipment or networks; and

- 3.14.4 supply of AC mains & UPS power, accommodation space, heating, ventilating, and air conditioning and other similar services and facilities at the POI or End User Premises.

Provisioning at an NBAP

3.15 A Standard Install for the Direct Fibre Access Service to an NBAP includes:

- 3.15.1 a Fibre Lead-in from the Fibre Access Point to an ETP at the closest convenient point on the NBAP, as agreed with End User, where the Fibre Lead-in utilises no more than:
- (a) 100m of approved conduit or open trench (already in place at the time of installation); or
 - (b) a single span of aerial drop lead (available only in areas where there is overhead deployment); or
 - (c) 15m of buried lead-in (available only in areas where there is underground deployment); and
- 3.15.2 an extension of the Fibre Lead-in up to 5m from the ETP (there will not necessarily be a break in the Fibre Lead-in at the ETP) to:
- (a) a suitable mounted SC/APC² connector at a secure location inside the NBAP; or
 - (b) if there is an OFDF beyond the ETP, a splice or LCA connector on the OFDF.

4 Service Demarcation Point at End User Premises

- 4.1 The service demarcation point at the End User's Premises is the 100/1000Base-T UNI on the ONT.
- 4.2 The Bitstream 3 Service excludes the End User Premises wiring. If a fault reported by the Service Provider is found to be caused by the End User Premises equipment (CPE) or the wiring at the End User's Premises beyond the service demarcation point, then the Service Provider may be charged the no fault found fee in the Price List. Note the wiring should comply with the industry standard Premises wiring requirements which are available at www.tcf.org.nz.

5 Service Demarcation Point at POI

- 5.1 The Bitstream 3 Service is delivered as a transparent VLAN (the logical service demarcation point) on the UFB Handover Connection located at the POI.
- 5.2 The physical service demarcation point is the MOFDF in the POI, which is part of the UFB Handover Connection Service.
- 5.3 The UFB Handover Connection Service is a separate service and is a prerequisite to the supply of the Bitstream 3 Service i.e. Service Provider's must first purchase and then continue to maintain a UFB Handover Connection Service at all times while taking the Bitstream 3 Service.

6 LFC and Service Provider Responsibilities

- 6.1 Other LFC and Service Provider responsibilities are detailed in the General Terms and the Operations Manual.

7 Fibre Diversity

- 7.1 The Bitstream 3 Service provides a single fibre between the Central Office and the End User's Premises.

² SC/APC – Standard Connector / Angle Polished Connector to IEC 61754-4

- 7.2 Diversity (a second or subsequent instance of the Bitstream 3 Service between the Fibre Access Point and the Central Office) will be available as an option for some but not all Premises. Standard Installation Service Levels do not apply to the provision of the diverse products and each instance will be treated as an individual line for the purpose of availability Service Levels.
- 7.3 Where available the diverse optical paths will be in separate fibre cable sheaths, and if requested in separate cable routes. The diverse cable routes will be a minimum of the width of a street apart, and should not share any manholes or access points. Separate entries into the Central Office will also be used where available.
- 7.4 The Service Provider can also request diverse access to End User Premises, or access to diverse Central Offices as part of a Non-Standard Install; however this will not be available in all cases.
- 7.5 There may be practical limitations to providing full physical diversity to some sites. The provision of a separate entry to an LFC Central Office will have unique site specific engineering considerations and may attract additional costs.

8 Bitstream 3 Service Levels

- 8.1 Service Levels for both the Layer 1 and Layer 2 components of the Bitstream 3 Service are set out in the Service Level Terms for the Bitstream Services.

Appendix A – Diagram

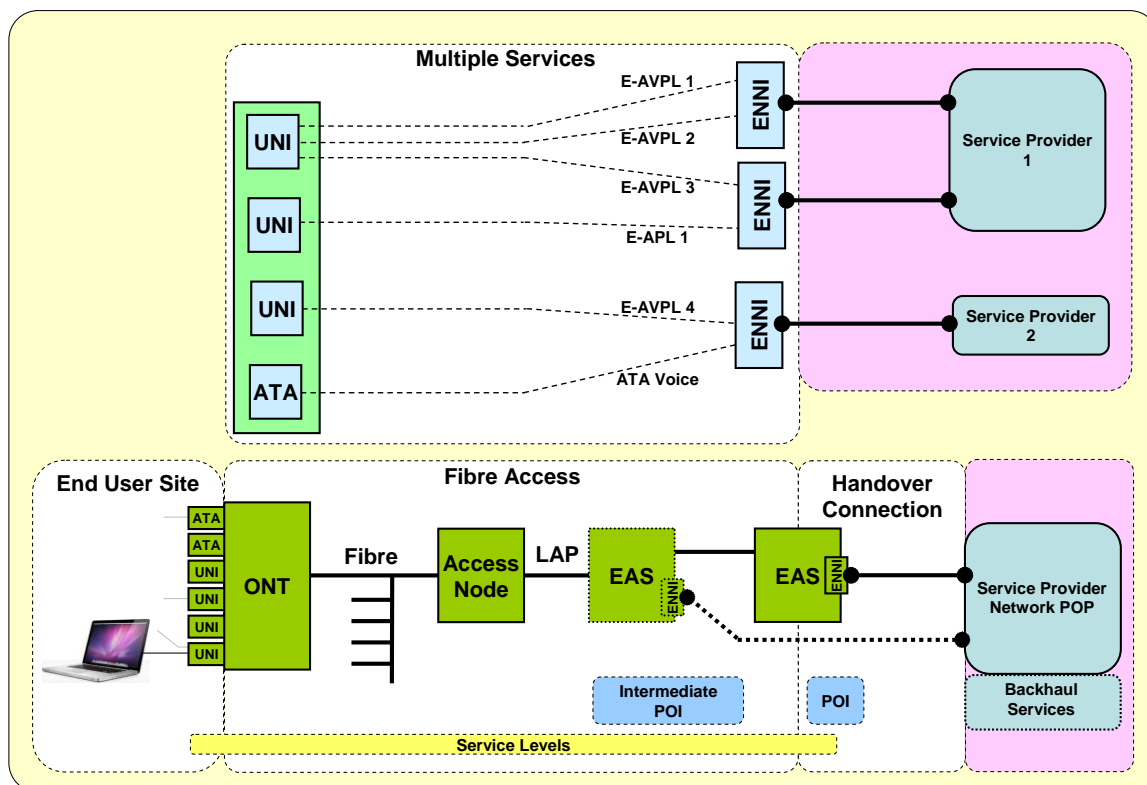

This is a generic diagram showing the standard configuration and service demarcation points. It is not intended to represent every situation or detailed physical architecture. The following points should be noted:

- The Bitstream 3 service and pricing applies from the UNI to the E-NNI at the POI, i.e. there is no incremental charge from the Intermediate POI to the POI.
- Some Bitstream services will have a single tier of aggregation, i.e. there is no Intermediate POI.
- Where there are multiple tiers of aggregation, the Service Provider can pick the service up at an Intermediate POI. This intermediate POI will service a limited Coverage Area.
- Service Levels (availability, network performance) only apply to UNI to the E-NNI at the POI.
- Access node and aggregation interconnection may use redundant links to meet Service Level requirements.

The Bitstream services support simultaneous delivery of multiple Service Templates from the same or multiple service providers as follows:

- Multiple E-AVPLs can be delivered to the same UNI;
- An E-APL service requires a dedicated UNI.
- An ATA Voice Service can be considered an E-AVPL with an ATA Voice port at the End User interface. The class and bandwidth characteristics of this E-AVPL are optimised for voice.
- All services delivered to a UNI must belong to the same Service Provider but can be mapped to the same or different E-NNIs.
- The initial Bitstream 3 Service Templates contain a single E-APL with 11 bandwidth options and one ATA Voice Service.

Appendix B – Technical Specification

Technical Specification	
Ethernet	<ul style="list-style-type: none"> • IEEE 802.3 – 2005 • 802.1q supporting 4093 VLANs
UNI	<p>ONT supports:</p> <ul style="list-style-type: none"> • 4 x UNI • 2 x ATA Voice ports • Optional additional ports: <ul style="list-style-type: none"> ○ RF Overlay port ○ WiFi <p>Per UNI:</p> <ul style="list-style-type: none"> • 100/1000Base-T
UFB Handover Connection (E-NNI)	<p>Ethernet:</p> <ul style="list-style-type: none"> • 802.1ad VLAN (SVID, CVID); or • Double tagged Q in Q.
VLAN	<p>Point-to-Point (E-APL) MTU 2000 Bytes Unicast Frame Delivery = Unconditional as per plan Multicast Frame Delivery = Unconditional as per plan Broadcast Frame Delivery = Unconditional as per plan Layer 2 Control Protocols Processing = Initially none (but may be amended by the LFC from time to time)</p>
Fibre	<p>External fibre must comply with ITU-T specification G.652D.</p> <p>Internal building fibres may comply with ITU-T G.657A. but must meet appropriate fire regulations.</p> <p>Fibre terminations must be SC/APC type connectors (complying with the IEC 61754-4 standard) or as an alternative LC/APC type connectors (complying with the IEC 61754-20 standard) as appropriate.</p> <p>Laser types and path characteristics expected to be designed to a minimum standard which are contained in the documents IEEE 802.3 Section 5 standard OR distance specifications as per the ITU-T G.984 (GPON) standard as appropriate.</p> <p>Testing for power loss will be at either 1310 or 1550 nm 1625 nm reserved for non disruptive testing</p>