



Enable Networks UFB Services Agreement
Bitstream Services:
Service Description for Baseband

1 Interpretation

- 1.1 The Baseband Service described in this Service Description will be available from the date it is launched by the LFC. The LFC will notify the Service Provider of the launch date for the Baseband Service.
- 1.2 References to clauses or sections are references to clauses or sections in this Service Description unless expressly provided otherwise. The definitions set out in the General Terms and the Operations Manual apply to this Service Description unless expressly provided otherwise.
- 1.3 References to the Operations Manual are references to the operations manual for the Bitstream Services.

2 The Baseband Service

- 2.1 The Baseband Service is a service to enable the delivery of PSTN analogue phone and telephony services over a GPON Fibre access from the End User Site to the Handover Point.
- 2.2 A diagram of the configuration for Baseband Service is set out in Appendix A. The Baseband Service delivers an analogue voice service from an End User Premises (or End User Tenancy in the case of an MDU) to a voice stream at a Handover Point that enables a Service Provider to interconnect with the LFC Network.
- 2.3 The Baseband Service is an input service which a Service Provider can combine with other LFC services (or with the Service Provider's own network or wholesale services provided by other service providers) to provide fibre based telecommunications services to End Users.
- 2.4 The Baseband Service has the following key characteristics:
 - 2.4.1 End Users can use any analogue PSTN-compatible CPE to use the Baseband Service. Facsimile and dialup modem support may be limited in some locations. The LFC will advise the Service Provider of these limitations from time to time.
 - 2.4.2 The Baseband Service is handed over at the POI as a bitstream VLAN as specified in clause 5.1 of this Service Description.
 - 2.4.3 Service Providers can either terminate the Baseband Service at the POI, typically using a carrier-grade voice switch, or use a compatible backhaul service to terminate the Baseband Service at a remote location.
 - 2.4.4 The Baseband Service can be delivered by itself, when used to provide an input to a voice service, or as part of a Service Template:
 - (a) Service Templates support the packaging of the Baseband Service with other Bitstream Services. For example Bitstream 2, Bitstream 3 and Bitstream 3a all offer default Service Templates that include the Baseband Service with one ATA Voice Service and at least one Bitstream Service. A Service Provider can choose whether to use the ATA Voice Service to support their retail voice service; or
 - (b) instead of using one of the default Service Templates defined in the service descriptions for the Bitstream Services, a Service Provider can create modified or new Service Templates using 'core building blocks' and the Product Development Process.
 - 2.4.5 The Baseband Service will only be delivered by itself (without a Bitstream 2, Bitstream 3 or Bitstream 3a service) in Greenfields subdivisions. The LFC may at its sole discretion allow a standalone Baseband Service in other situations.

3 Baseband Service and implementation activities

Installation Services

3.1 The Baseband Service includes a Standard Install as set out below (in each case to the extent that the relevant provisioning works are not already complete for the relevant Service Order).¹

Provisioning at Single Dwelling Unit End User's Premises

3.1.1 A Standard Install for the Baseband Service to a Single Dwelling Unit includes:

- (a) a Fibre Lead-in from the Fibre Access Point to an ETP at the closest convenient point on the End User Premises, as agreed with the End User, where the Fibre Lead-in utilises no more than:
 - (i) 100m of approved conduit or open trench (already in place at the time of installation); or
 - (ii) a double span of aerial drop lead on existing poles from the Fibre Access Point (this will include road crossings and is available only in areas where there is overhead deployment); or
 - (iii) 30m of buried lead-in (available only in areas where there is underground deployment); and
- (b) an extension of the Fibre Lead-in up to 10m radius from the ETP (there will not necessarily be a break in the Fibre Lead-in at the ETP) to:
 - (i) a suitable mounted SC/APC connector at a secure location inside the End User Premises; or
 - (ii) if there is an OFDF beyond the ETP, a splice or LCA connector on the OFDF.

3.1.2 The LFC will provide Non-Standard Installs for the Baseband Service to Single Dwelling Units as an Ancillary Service.

Provisioning at MDU End User's Premises

3.1.3 A Standard Install for the Baseband Service to an End User that is within a MDU (i.e. an End User Tenancy) includes:

- (a) a Fibre Lead-in from the Fibre Access Point to the OFDF or equivalent at the closest convenient point within the MDU, as agreed with the MDU owner or their agent, where the Fibre Lead-in utilises no more than:
 - (i) 100m of approved conduit or open trench (already in place at the time of installation);
 - (ii) a double span of aerial drop lead on existing poles from the Fibre Access Point (this will include road crossings and is available only in areas where there is overhead deployment); or
 - (iii) 30m of buried lead-in (available only in areas where there is underground deployment); and
- (b) where the fibre cabling in a MDU to the End User Tenancy is not already in place at the time of installation of the Baseband Service, fibre cabling within the MDU to extend the Fibre-Lead-in from the OFDF or equivalent to the End-User Tenancy; and

¹Standard Install parameters may differ between LFCs.

- (c) either:
 - (i) a further extension of the Fibre Lead-in up to a 10m radius from the ETP at the End User Tenancy (there will not necessarily be a break in the Fibre Lead-in at the ETP) to:
 - (A) a suitable mounted SC/APC connector at a secure location; or
 - (B) if there is an OFDF beyond the ETP, a splice or LCA connector on the OFDF,
 - within the End User Tenancy; or
 - (ii) if there is not an ETP at the End User Tenancy as contemplated by clause 3.1.3(c)(i), an extension of the Fibre Lead-in up to a 10m radius from the boundary of the End User Tenancy to:
 - (A) a suitable mounted SC/APC connector at a secure location; or
 - (B) if there is an OFDF beyond the boundary, a splice or SC/APC plug on the OFDF,
 - within the End User Tenancy.

3.1.4 The extended LFC Network fibre within the MDU is the Fibre Lead-in to an End User Tenancy, whether currently in use or not. The Fibre Lead-in is only available for use by the LFC.

3.1.5 The LFC will provide Non-Standard Installs for the Fibre Lead-in to End User Tenancies within MDUs as an Ancillary Service.

Single Dwelling Unit Termination Point

3.1.6 For a Single Dwelling Unit, the termination point of the Layer 1 component of the Baseband Service for the purposes of the Connection at the End User's Premises, and the network demarcation point between the LFC Network and the Premises wiring is, as applicable, either:

- (a) the SC/APC connector on the end of the Fibre Lead-in from the ETP (which is the connector); or
- (b) if there is an OFDF beyond the ETP, a splice or LCA connector on the OFDF,
 - provided that any ONT installed by the LFC as part of the Baseband Service will also be part of the LFC Network.

3.1.7 The termination point of the Layer 2 component of the Baseband Service is the 100/1000 Base-T UNI on the ONT.

MDU Termination Point

3.1.8 For MDUs, the termination point of the Layer 1 component of the Baseband Service for the purposes of the Connection at the End User's Tenancy, and the network demarcation point is, as applicable, either:

- (a) the SC/APC connector on the end of the Fibre Lead-in (which is the jack); or
- (b) if there is an OFDF beyond the ETP or End User Tenancy boundary, a splice or LCA connector on the OFDF,
 - within the End User Tenancy provided that any ONT installed by the LFC as part of the Baseband Service will also be part of the LFC Network.

3.1.9 The termination point of the Layer 2 component of the Baseband Service is the 100/1000 Base-T UNI on the ONT.

Alternative Termination Points

3.1.10 The LFC and the Service Provider may agree on a different termination point as part of a Non-Standard Install. This may be necessary where, for example, there is installation to a NBAP. A Non Standard Install for a Baseband Service within a Multi Dwelling Unit will not include termination in a building common area or other facility made available by the owner to service the Multi Dwelling Unit, where a Fibre Lead-in has not been extended from the OFDF to the inside of an End User Tenancy.

Installation of ONT

- 3.1.11 A Standard Install for the Baseband Service includes installation of an ONT including:
- (a) supply and fixing of the ONT to the structure of the End User Premises (in the case of a Single Dwelling Unit) or an End User Tenancy (in the case of an MDU);
 - (b) supply and connection of fibre pigtail up to 1m long between the Fibre Lead-in termination point and the ONT if required; and
 - (c) testing from the UNI port of the ONT to ensure the Baseband Service is within the technical specification set out in Appendix B.
- 3.1.12 The Service Provider must ensure the End User provides a suitably located mains power outlet for the ONT power supply which is not provided as part of a Standard Installation.
- 3.1.13 The End User must provide space and power within their Footprint for the ONT. The location of the ONT must be a suitable environment for electronic equipment with generally a dry, clean indoor area with adequate ventilation.

Testing

3.2 The LFC will test the Fibre Lead-in from the termination point at the End User's Premises referred to in clause 3.1.6, 3.1.8 or 3.1.10 to the Central Office where the access node is located to ensure the fibre is within the technical specification for fibre set out in Appendix B.

Additional Services

- 3.3 If the Service Provider requires additional services such as:
- 3.3.1 A Non-Standard Install which includes (where required):
- (a) an extension of the Fibre Lead-in over the maximum distances specified in clauses 3.1.1 (in relation to Single Dwelling Units) or 3.1.3 (in relation to End User Tenancies within MDUs);
 - (b) installation to a NBAP utilising specialised termination equipment; or
 - (c) installation of Fibre-Lead-in diversity at an End User's Premises (from the FAP to the ETP or OFDF as applicable);
- 3.3.2 Premises wiring services; or
- 3.3.3 Installation and testing of Service Provider equipment and services,
- then the LFC may be able to provide the services in clauses 3.3.2 and 3.3.3 on request subject to terms to be agreed between the LFC and the Service Provider. The services in clause 3.3.1 are available on terms as set out in this Agreement.

Core Baseband Service

- 3.4 The core Bitstream Services provided as part of the Baseband Service are as follows:
- 3.4.1 An ATA Voice Service at the End User Premises via an RJ11 ATA Voice port on an ONT; and
- 3.4.2 Provided via a GPON shared fibre access as follows:

Access Technology	Description	Supported Bitstream	Interface Options
-------------------	-------------	---------------------	-------------------

Access Technology	Description	Supported Bitstream	Interface Options
ATA Voice over Fibre (as described in the ATA Voice Service Description).	An ATA port on an ONT that converts Analogue Voice into a SIP or H.248 Bitstream Service. Handed over as a VLAN Bitstream Service.	Bitstream 2, Bitstream 3, Bitstream 3a, Multicast	Bitstream

- 3.5 The Baseband Service supports the ATA Voice Service.
- 3.6 The Baseband Service may be ordered by the Service Provider in one of the following combinations:
- 3.6.1 The Baseband Service on its own, suitable for a voice-only service;
- 3.6.2 A Service Template that combines Baseband with the Bitstream Services defined in the Service Descriptions for the Bitstream 2; Bitstream 3 and Bitstream 3a Services.
- 3.7 The Baseband Service may be offered in conjunction with future bitstream services that are developed and offered by the LFC subject to terms to be agreed between the LFC and the Service Provider.
- 3.8 A Service Provider may request the creation by the LFC of additional Service Templates by combining Baseband with Bitstream services using the Product Development Process. The Product Development Process includes determination of pricing, development, testing and implementation.
- 3.9 The LFC will comply with the Service Provider's request under clause 3.8 in a timely manner. In the event that demand for new Service Templates exceeds the LFC's capacity to deliver the new Service Templates then the LFC may prioritise the Service Template requests in accordance with the Operations Manual.

Service Requirements

- 3.10 To use the Baseband Service the Service Provider must have the capability to access and interconnect with it, by one of the following:
- 3.10.1 Co-locating Service Provider equipment at the POI using the UFB Handover Connection Service and Central Office and POI Co-location Service;
- 3.10.2 Connecting to third party co-location space at the POI using the UFB Handover Connection Service, and with the third party taking the Central Office and POI Co-location Service;
- 3.10.3 Connecting to a backhaul service at the POI; or
- 3.10.4 By using the Direct Fibre Access Service to connect to Service Provider equipment at a remote location within the Central Office area.

Additional Service Characteristics

- 3.11 The technical specification of the Baseband Service is set out in Appendix B.
- 3.12 The LFC will provide certain support and other assistance as part of the Baseband Service including:
- 3.12.1 An automated facility for Service Requests;
- 3.12.2 An automated facility for fault notifications; and
- 3.12.3 A tool to assist the Service Provider in determining the location and availability of the Baseband Service (pre-qualification),
- each as more particularly set out in the Operations Manual.
- 3.13 The Baseband Service specifically excludes:
- 3.13.1 The UFB Handover Connection Service;
- 3.13.2 Provision or maintenance of any cabling or connection or active device:

- (a) beyond the service demarcation points described in clauses 4.1 and clause 5.1;
 - (b) between the jack terminating the LFC provided Fibre Lead-in and the ONT where that cabling or connection is not provided by the LFC and the LFC has not agreed to take responsibility for that cabling or connection.
- 3.13.3 Configuration, monitoring, operation, on-going support or maintenance of Service Providers' or End Users' applications, equipment or networks; and
- 3.13.4 Supply of AC mains & UPS power, accommodation space, heating, ventilating and air conditioning and facilities at the POI or End User Premises.

Provisioning at an NBAP

- 3.14 A Standard Install for the Baseband Service to an NBAP includes:
- 3.14.1 A Fibre Lead-in from the Fibre Access Point to an ETP at the closest convenient point on the NBAP, as agreed with End User, where the Fibre Lead-in utilises no more than:
- (a) 100m of approved conduit or open trench (already in place at the time of installation); or
 - (b) a double span of aerial drop lead on existing poles from the Fibre Access Point (this will include road crossings and is available only in areas where there is overhead deployment); or
 - (c) 30m of buried lead-in (available only in areas where there is underground deployment); and
- 3.14.2 An extension of the Fibre Lead-in up to 10m radius from the ETP (there will not necessarily be a break in the Fibre Lead-in at the ETP) to:
- (a) a suitable mounted SC/APC² connector at a secure location inside the NBAP; or
 - (b) if there is an OFDF beyond the ETP, a splice or LCA connector on the OFDF.
- 3.14.3 The LFC will provide Non-Standard Installs for the Baseband Service to an NBAP as an Ancillary Service.

4 Service Demarcation Point at End User Premises

- 4.1 Baseband is always delivered with ATA Voice and ATA Voice is delivered to the RJ11 port on the ONT, as per the ATA Voice specification.
- 4.2 The Baseband Service excludes the End User Premises wiring. If a fault reported by the Service Provider is found to be caused by the End User Premises equipment (CPE) or the wiring at the End User's Premises beyond the service demarcation point, then the Service Provider may be charged the no fault found fee in the Price List. Note the wiring should comply with the industry standard premises wiring requirements which are available at www.tcf.org.nz.

5 Service Demarcation Point at POI

- 5.1 Baseband is always delivered with the ATA Voice Service and ATA Voice is delivered as a single VLAN (the logical service demarcation point) on the UFB Handover Connection Service located at the POI, as per the ATA Voice Service specification.
- 5.2 The physical service demarcation point is the MOFDF in the POI, which is part of the UFB Handover Connection Service.

²SC/APC – Standard Connector/Angle Polished Connector to IEC 61754-4.

- 5.3 The UFB Handover Connection Service is a separate service and is a prerequisite to the supply of the Baseband Service i.e. the Service Provider must first purchase and then continue to maintain a UFB Handover Connection Service at all times while taking the Baseband Service.

6 LFC and Service Provider Responsibilities

- 6.1 Other LFC and Service Provider responsibilities are detailed in the General Terms and the Operations Manual.

7 Baseband Service Levels

- 7.1 Service Levels for both the Layer 1 and Layer 2 components of the Baseband Service are set out in the Service Level Terms for the Bitstream Services.

Appendix A – Diagram

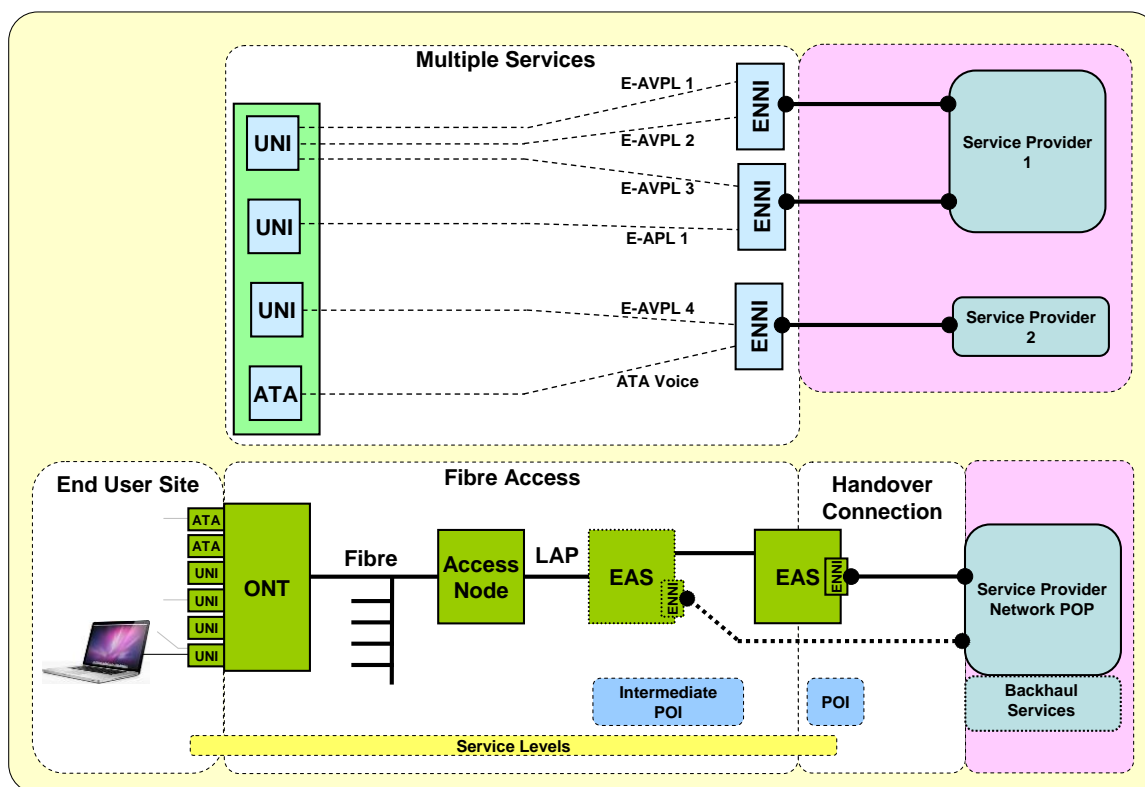

This is a generic diagram showing the standard configuration and service demarcation points. It is not intended to represent every situation or detailed physical architecture. The following points should be noted:

- The Baseband service and pricing applies from the UNI to the E-NNI at the POI, i.e. there is no incremental charge from the intermediate POI to the POI.
- Some Bitstream Services will have a single tier of aggregation, i.e. there is no intermediate POI.
- Where there are multiple tiers of aggregation, the Service Provider can pick the service up at an intermediate POI. This intermediate POI will service a limited Coverage Area.
- Service Levels (availability, network performance) only apply to UNI to the E-NNI at the POI.
- Access node and aggregation interconnection may use redundant links to meet Service Level requirements.

The Bitstream services support simultaneous delivery of multiple Service Templates from the same or multiple service providers as follows:

- Multiple E-AVPLs can be delivered to the same UNI.
- An E-APL service requires a dedicated UNI.
- An ATA Voice Service can be considered an E-AVPL with an ATA Voice port at the End User interface. The class and bandwidth characteristics of this E-AVPL are optimised for voice.
- All services delivered to a UNI must belong to the same Service Provider but can be mapped to the same or different E-NNIs.

Appendix B – Technical Specification

Technical Specification

End User Premises	
ATA Voice over fibre	RJ11. Analogue interface compliant with PTC 220, section 5.
Handover Point	
UFB Handover Connection	802.1ad VLAN or double-tagged QnQ. PCP = 4. Voice (See ATA Service Description for additional information): <ul style="list-style-type: none">• SIP.